

Technical Data Sheet

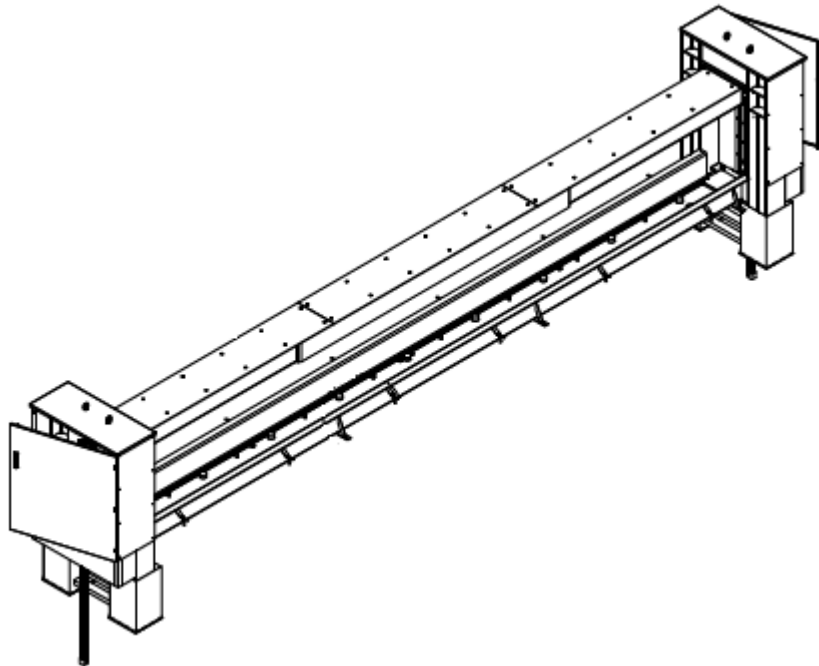

- Design:** Barrier Lift System with electro-hydraulic drive in separate drive cabinet, guide stands, ground sleeves, horizontal crash beam and ground frame for installation in roadway.
- Impact Load:** 1699 kJ (6.8 t @ 50 mph)
Crash test certified according to DOD SD-STD-02.01 Rev. A 03/2003 K12/L2
- Clear Width of Opening (CWO):** 6.0 m, 7.0 m, 8.0 m, 9.0 m and 10.0 m
- Blocking Height:** 1100 mm
- Crash Beam:** Rectangular hollow section profile RHS 450x250 with cover plate
- Guide Stands:** H x W x D: 2213 mm x 1293 mm x 571 mm (height without hydraulic cylinder), height above foundation: 1713 mm
- Ground Frame:** L x W x H: (CWO + 24 mm) x 880 mm x 310 mm (width without anchors, height without 150 mm high drainage sleeves)
Total width approx. 1013 mm
- Ground Sleeves:** H x W x D: 654 mm x 1370 mm x 400 mm (height without fastening bolts)
- Drive Cabinet:** H x W x D: 1400 mm x 1200 mm x 400 mm incl. 200 mm high base (standard / RO1 for non EU and non EFTA countries)
H x W x D: 1800 mm x 1200 mm x 500 mm incl. 200 mm high base (RO1 for EU and EFTA countries)
- Emergency Operation:** Via hand pump (standard)
Accumulator incl. rechargeable batteries for one movement (RO1) (optional)
- Operating Speed:** Raising: approx. 0.17 m/sec
Lowering: approx. 0.20 m/sec

Technical Data Sheet

Wheel Load:	100 kN according to SLW60 – DIN 1072
Drive:	4.0 kW, 400 V (three-phase), 50 Hz
Hydraulic Fluid:	Mineral oil HLP 22 or biodegradable oil Plantohyd 22 S, non-hazardous to water
Control Unit:	PLC in control box installed in drive cabinet (standard), PLC in separate control box for wall mounting inside a building (optional), control voltage 24 V
Supply Voltage:	400 V (3Ph + N + PE), 50 Hz
Weight:	Approx. 1610 – 2130 kg (crash beam) Approx. 2560 kg (guide stands and ground sleeves) Approx. 650 – 960 kg (ground frame) Approx. 280 – 400 kg (drive cabinet)
Colour (Standard):	Crash beam RAL 9010 pure white Cover plate crash beam RAL 9010 pure white Guide stands RAL 9010 pure white Ground frame RAL 9010 pure white Ground sleeves primed (dark grey) Drive cabinet RAL 7035 light grey
Colour (Optional):	Crash beam Striped RAL 3000 flame red / RAL 9010 pure white RAL 3000 flame red or other RAL colours or DB colours Cover plate crash beam other RAL colours or DB colours Guide stands other RAL colours or DB colours Ground frame other RAL colours or DB colours
Temperature Range:	-20°C to + 60°C